

NOTE: remember to add 0.1uF capacitor to all high-speed ICs (74F269, TLC5540, CY7C109B) Vcc

Title: Bloque principal		
Osciloscopio USB		
Designed by:	Document N: 0001	Revision: 10
Checked by:	Date: 2005-12-05	Size: Custom
Approved by:	Sheet 1 of 5	

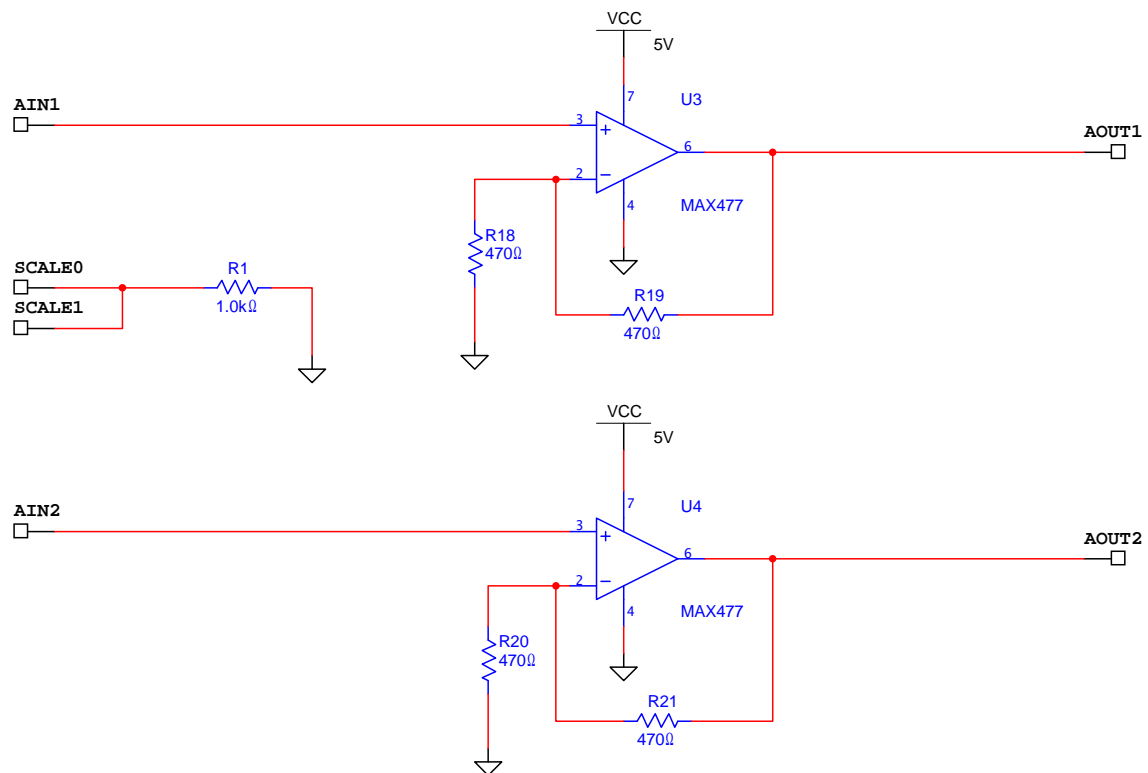

Title: Etapa de Entrada		
Osciloscopio USB		
Designed by:	Document N: 0001	Revision: 10
Checked by:	Date: 2005-12-05	Size: Custom
Approved by:	Sheet 2 of 5	

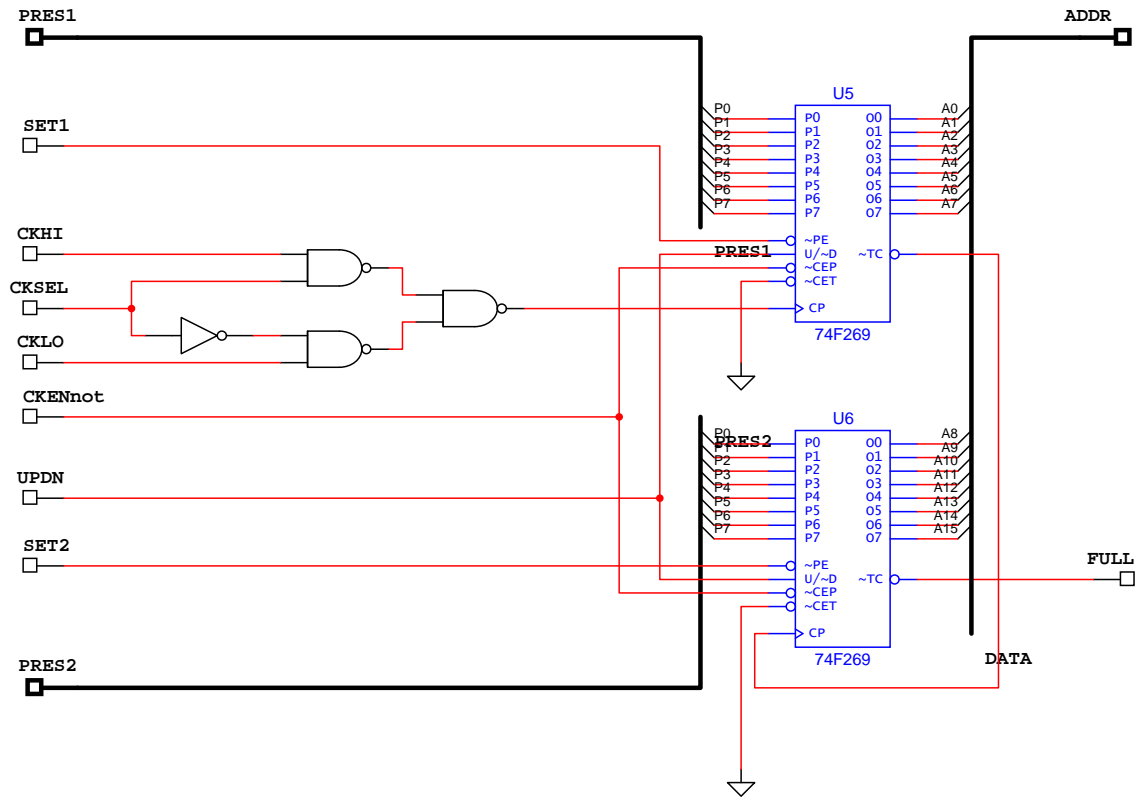

Title: Control de memoria		
Osciloscopio USB		
Designed by:	Document N: 0001	Revision: 10
Checked by:	Date: 2005-12-05	Size: Custom
Approved by:	Sheet 3 of 5	

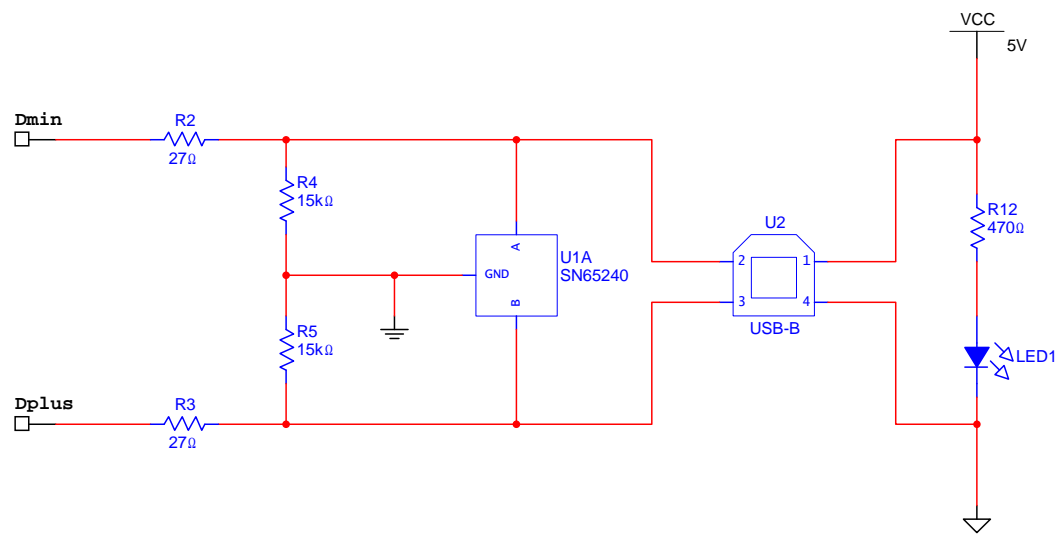

Title: Salida USB		
Osciloscopio USB		
Designed by:	Document N: 0001	Revision: 10
Checked by:	Date: 2005-12-05	Size: Custom
Approved by:	Sheet 4 of 5	

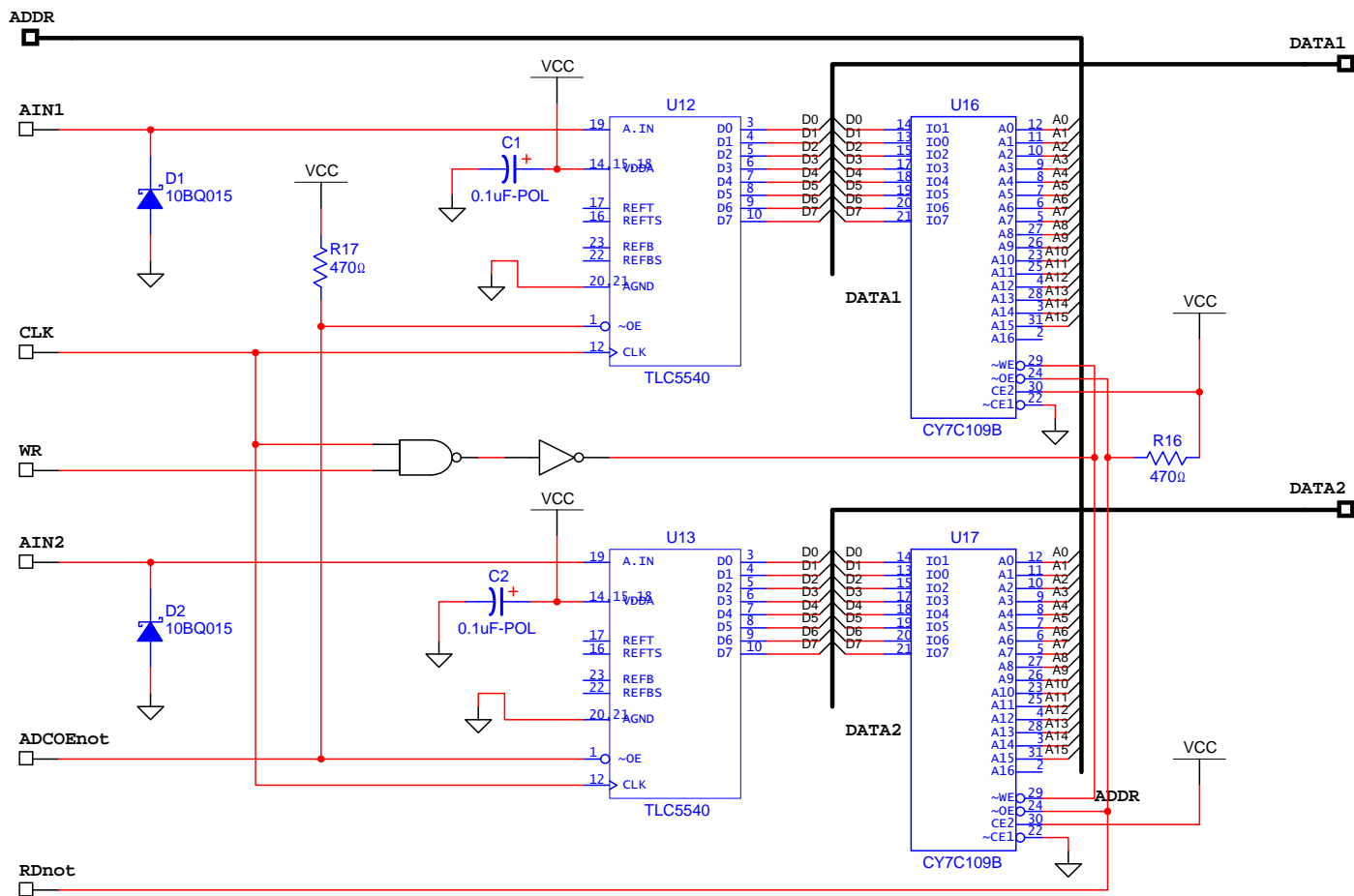

Title: Adquisición		
Osciloscopio USB		
Designed by:	Document N: 0001	Revision: 10
Checked by:	Date: 2005-12-05	Size: Custom
Approved by:	Sheet 5 of 5	